



Flowmeters with clear plastic tubes

Series PT-11/PT-12

Plastic Flow Meters for gases & liquids, using TROGAMID* & POLYSULFONE Technology

Applications

Monitoring & Control of processes for:

- Water & Waste Water Treatment
- Chemical, Petrochemical & Paper
- Pharmaceutical, Cosmetics & Synthesis
- Refrigeration & Air Conditioning
- Refining
- Osmosis
- Gas processes

Benefits

- Low cost
- Excellent readability
- Scaled directly in l/h, m³/h, %, etc.
- Temperatures up to 60°C TROGAMID*, and 90°C POLYSULFONE
- Pressures up to 15 bar
- Simple installation (flanged, threaded or glued connections)
- Light weight
- High & Low Flow Switches
- 4-20 mA Output (18 points max.)
(On request HART, PROFIBUS, FIELDBUS protocols)

* TROGAMID is a registered trade mark of Dynamit Nobel.



Series PTM-01/PTM-02



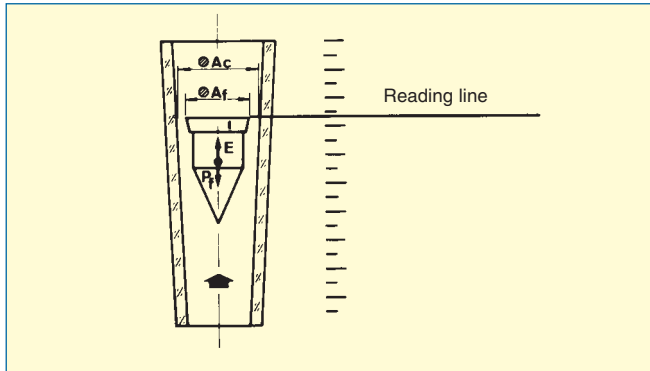

Type AC Type ACT

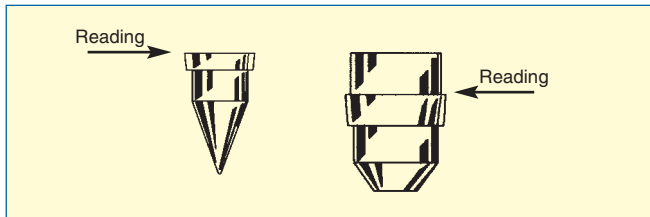

Measurement Principle

Variable area flow using a float in a tapered tube made from special plastic materials.

Operation

The fluid flows up through the tapered tube forcing the float to a position with sufficient free area to enable the flow to pass. This free area is related to the flow rate, the weight of the float and the density and viscosity of the fluid.

The pressure drop across the flow meter remains constant over the entire flow range. This occurs because the pressure drop is related to the fluid velocity and area of flow, the area of flow increases as the flow rate increases.

Technical Data

- Connections:
 - PT-11 & PS-31:** Threaded or glued fittings from 1/2" to 3" BSPF
 - PT-12 & PS-32:** Flanges DN 15 to DN 80, PN 10
 - PTM-01 & PSM-21:** Threaded or glued fittings of 1/2" and 3/4" BSPF
 - PTM-02 & PSM-22:** Flanges DN 15 and DN 20, PN 10
 Other connections available on request
- Length (in mm)

	Minimum	Maximum
PT-11	340	414
PT-12	390	538
PT-12 (BR)	380	420
PTM-01 / PSM-21	232 ± 1 mm	
PTM-02 / PSM-22	260 ± 1 mm	
- Accuracy:
 - PT & PS:** According to Standards VDE / VDI Class 4
 - PTM & PSM:** According to Standards VDE / VDI Class 6
- Scales calibrated directly in l/h, m³/h, %
- Scale length:
 - PT & PS:** 160 ± 5 mm
 - PTM & PSM:** 100 ± 5 mm
- Rangeability: 10:1
- Pressure: up to 15 bar @ 20°C

NOTE: a more cost effective PTM Series flow meter is available from stock, the model PTM-03 with NAS[®] 30 clear performance plastic. Available flow rates and options, same as PTM Series.

NAS[®] is a registered trade mark of NOVA Chemicals Inc.

- Temperature Limits:
 - PT-TROGAMID T tubes: 60°C
 - PS-POLYSULFONE tubes: 90°C
 - PTM-TROGAMID T tubes: 60°C
 - PSM-POLYSULFONE tubes: 90°C
- PVC fittings: max. 55°C
- PP fittings: max. 90°C
- Materials:

Flow tube	Fittings	Float	Float Stops
PT-TROGAMID T		EN 1.4404 (SS-316L) PVDF+ Lead	
PS-POLYSULFONE	PVC PP	Aluminium PTFE	PVDF
PTM-TROGAMID T	SS-316L Steel	PTFE+Lead PVC	
PSM-POLYSULFONE		PVC + Lead	

- Alarm Options:
 - PT-AMR 1...2 Magnetic actuated reed switch
- Transmitter Options:
 - PT-TMUR 0...4-20 mA
(16...18 points resolution for Series PT-PS)
 - PTM-TMUR 0...4-20 mA
(11 points resolution for Series PTM-PSM)

PT-11, PS-31/PTM-01, PSM-21

PT-12, PS-32/PTM-02, PSM-22

PT-12(BR), PS-32(BR)

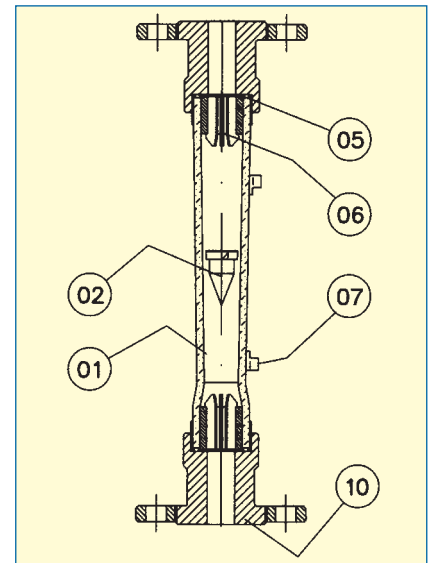
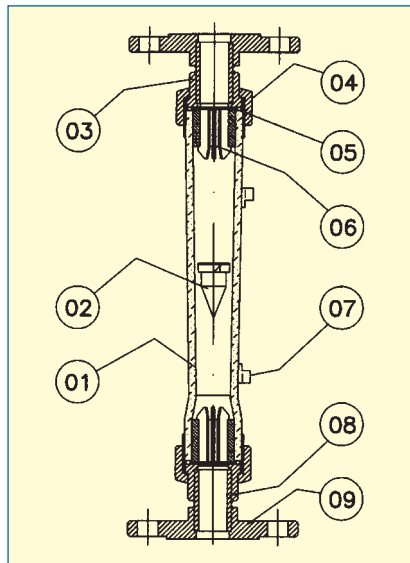
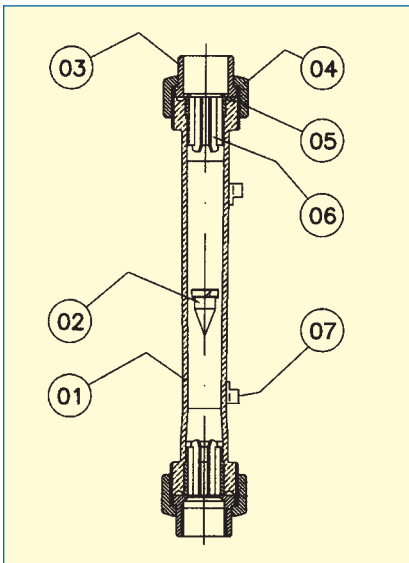

N°	Item	PT-11/12,PTM-01/02,PT-12(BR)	PS-31/32,PSM-21/22,PS-32(BR)	On demand
1	Flow tube	TROGAMID T	POLYSULFONE	PVDF
2	Float	EN 1.4404 (SS-316L), PVDF+Lead, Aluminium	EN 1.4404 (SS-316L), PVDF+Lead, Aluminium	PTFE, PTFE+Lead, Hastelloy, Titanium
3	Fitting	PVC	PVC	PP, Steel, SS-316L
4	Nut	PVC	PVC	PP, Steel, SS-316L
5	Gasket	NBR	NBR	Viton, EPDM
6	Float Stop	PVDF	PVDF	-
7	Flow Indicator	PVC	PVC	-
8	Tube Union	PVC	PVC	-
9	Flange (glued)	PVC	PVC	-
10	Flange Neck	PVC	PVC	PP



PT + PT-TMUR



PTM + PTM-TMUR



PT + PT-AMR



PTM + PTM-AMR



PT-11 / PS-31 ... PT-12 / PS-32 ... PT-12(BR) / PS-32(BR)

Flow Tube Series PT Series PS*	Measuring Ranges vs Float Type AC						Max. Operating Pressure bar	ΔP mm H ₂ O		Tube Length mm (±1mm)	Series	
	EN 1.4404 7.95 g/cm ³			ALUMINIUM 2.85g/cm ³				Float			DN	E
	Water 20°C l/h		Air@STP Nm ³ /h	Air@STP Nm ³ /h		EN 1.4404		ALUM.				
Model N°	Min.	Max.	Min.	Max.	Min.	Max.						
PT-312-0160 ^{(1)*}	16	160	-	-	0.6	6	15	90 ⁽¹⁾	-	300	15	20
PT-312-0250 ^{(1)*}	25	250	-	-	1	10	15	90 ⁽¹⁾	-	300	15	20
PT-313-0400*	40	400	1.1	11	0.7	7	15	125	50	300	20	25
PT-313-0630*	60	630	1.8	8	1	10	15	125	50	300	20	25
PT-313-1000*	100	1000	3	30	1.7	17	15	125	50	300	20	25
PT-314-1600*	160	1600	4.5	45	2.5	25	10	175	75	300	25	32
PT-314-2500*	250	2500	7	70	4	40	10	175	75	300	25	32
PT-315-4000*	400	4000	11	110	7	70	10	230	95	300	40	50
PT-315-6300*	500	6300	18	180	10	100	10	230	95	300	40	50
PT-316-6300	500	6300	18	180	10	100	10	300	125	300	50	63
PT-316-M010*	1000	10000	30	300	17	170	10	300	125	300	50	63
PT-316-M014*	2000	14000	120	420	45	200	10	300	125	300	50	63
PT-317-M016	1600	16000	45	450	25	250	8	400	170	300	65/80	75/90
PT-317-M020	2000	20000	60	600	35	350	8	400	170	300	65/80	75/90
PT-317-M025	2500	25000	70	700	40	400	8	400	170	300	65/80	75/90
PT-317-M030	3000	30000	90	900	50	540	8	400	170	300	65/80	75/90
PT-317-M040	6000	40000	180	1200	100	712	8	400	170	300	65/80	75/90
PT-317-M040 ⁽³⁾	8000	50000	240	1500	150	900	8	400	170	300	65/80	75/90

(1) With PTFE float

(2) NOTE: for PT and PS Series, all plastic loaded floats are in PVDF+Lead, except for the tubes with model n° PT-316-M014, PT-317-M016, PT-317-M020, PT-317-M025, PT-317-M030, PT-317-M040 where the material for the float is PVC+Lead

(3) Fits special float to reach higher flow rate

* Flow tube available in Polysulfone

PTM-01 / PSM-21 ... PTM-02 / PSM-22

Flow Tube Series PTM Series PSM*	Measuring Range vs Float Type AC						Max. Pressure bar	Pressure Drop ΔP mm Water		Tube Length mm (±1mm)	Series	
	EN 1.4404 ⁽¹⁾ 7.95 g/cm ³			Aluminium 2.85 g/cm ³				Float			DN	E
	Water 20°C l/h		Air @ STP Nm ³ /h	Air @ STP Nm ³ /h		EN 1.4404 ⁽¹⁾		Al				
Model N°	Min.	Max.	Min.	Max.	Min.	Max.						
PTM-312-0040 ^{(2)*}	4	40	-	-	0.12	1.5	15	30 ⁽²⁾	-	192	15	20
PTM-312-0060 ^{(2)*}	6	60	-	-	0.2	2	15	30 ⁽²⁾	-	192	15	20
PTM-312-0100*	10	100	0.3	3	0.15	1.8	15	90	35	192	15	20
PTM-312-0160*	16	160	0.5	5	0.25	2.5	15	90	35	192	15	20
PTM-312-0250*	25	250	0.7	7	0.4	4	15	90	35	192	15	20
PTM-313-0400*	40	400	1.1	11	0.7	7	15	125	50	192	20	25
PTM-313-0630*	60	630	1.8	8	1	10	15	125	50	192	20	25
PTM-313-1000*	100	1000	3	30	1.7	17	15	125	50	192	20	25

(1) EN 1.4404 = SS-316L

(2) With PTFE float

* Flow tube available in Polysulfone

PT-11 / PS-31

Rp" = DN	E	RE	A	L	L1	L2	H
1/2"	15	20	1"	43	340	300	307
3/4"	20	25	1 1/4"	53	346	300	309
1"	25	32	2"	74	352	300	311
1 1/2"	40	50	2 1/4"	80	366	300	314
2"	50	63	2 3/4"	99	372	300	314
2 1/2"	65	75	4"	135	378	300	318
3"	80	90	4"	135	414	300	318

PT-12 / PS-32 & PT-12(BR) / PS-32(BR)

DN	E	D	k	g	l _{xn} ^o	B	L	L(BR)
15	20	95	65	45	14x4	12	390	380
20	25	105	75	58	14x4	13	396	380
25	32	115	85	68	14x4	15	412	390
40	50	150	110	88	18x4	17	446	400
50	63	165	125	102	18x4	20	458	41
65	75	185	145	122	18x4	21	490	420
80	90	200	160	138	18x4	22	538	420

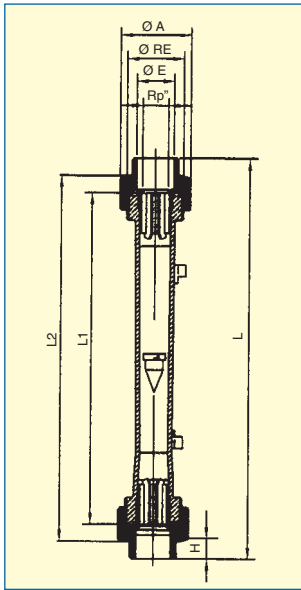
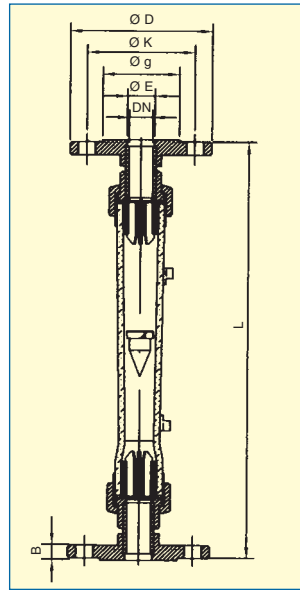
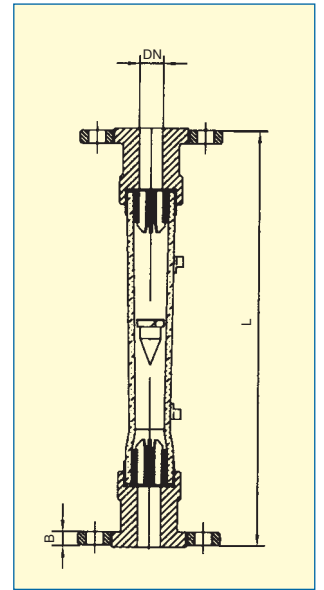
**PT-11
PS-31**

**PT-12
PS-32**

**PT-12(BR)
PS-32(BR)**

PTM-01 / PSM-21

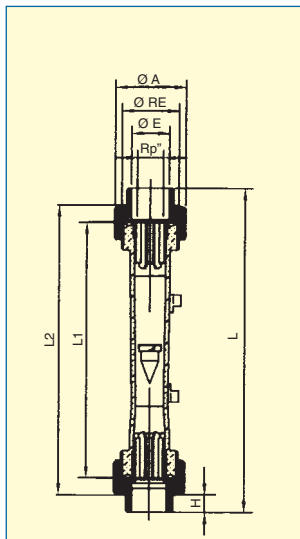
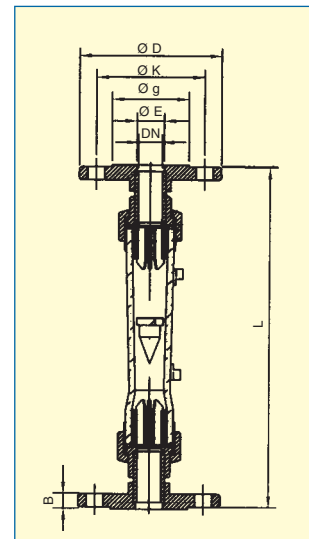
Rp" = DN	E	RE	A	L	L1	L2	H
1/2"	15	20	1"	43	232	192	198
3/4"	20	25	1 1/4"	53	232	192	198

PTM-02 / PSM-22

DN	E	D	k	g	l _{xn} ^o	B	L
15	20	95	65	45	14x4	12	257
20	25	105	75	58	14x4	13	260

**PTM-01
PSM-21**

**PTM-02
PSM-22**

Adjustable Limit Switches PT-AMR

(from 25-250 l/h H₂O, and 0.8-8 Nm³/h air)

Adjustable Limit Switches PTM-AMR

(from 6-60 l/h H₂O, and 0.2-2 Nm³/h air)

Reed switch, actuated by a magnet inside the float.

- Mounted within a PVC enclosure:
PT-AMR & PTM-AMR 1...2 Adjustable reed switches
- Operation:
The contact is normally open, when not in alarm condition
- Maximum Flow:
On increasing flow, the contact closes when the float reaches the height of the alarm sensor. It remains closed while the float is above the sensor. It opens again when the flow reduces and the float returns below the sensor.
- Minimum Flow:
On reducing flow, the contact closes when the float reaches the height of the alarm sensor. It remains closed while the float is below the sensor. It opens again when the flow increases and the float rises above the sensor.

Normally Closed reed switches are available on order.

Electrical Connection

In the female connector (A):

- Terminal 1: Reed switch contact
- Terminal 2: Reed switch contact
- Terminal 3: No connection
- Earth terminal: No connection

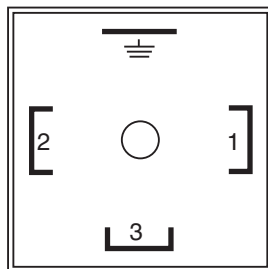

Mounting

Once the electrical connection has been made and the cable gland has been tightened, mount the female connector (A) on the male base (C), placing the seal (B) between the two pieces.

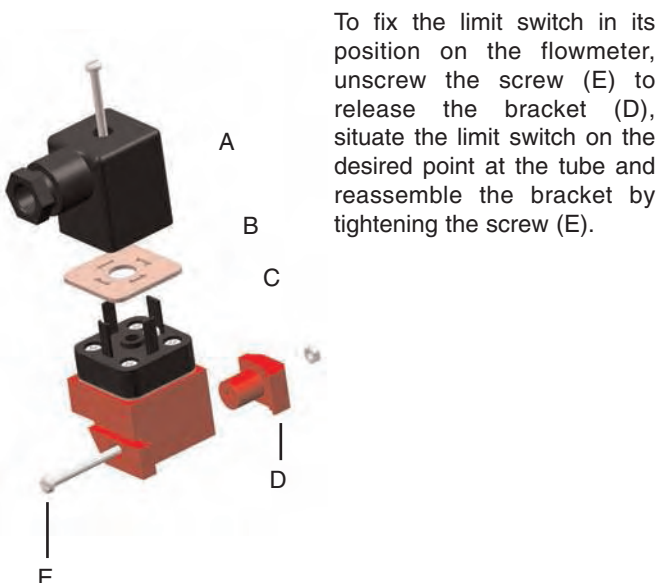

To fix the limit switch in its position on the flowmeter, unscrew the screw (E) to release the bracket (D), situate the limit switch on the desired point at the tube and reassemble the bracket by tightening the screw (E).

Technical Characteristics

- Material: PVC housing
- Ambient temperature: -15 to 60°C
- Contact rating: 0.5 A / 250 VDC / 12 VA
- Hysteresis: ±5% of full scale value
- Ingress protection degree: IP65
- DIN 43650-A connector, PG9 cable gland
- Conforms to 73/23/EEC Directive



PT-11/12...PS-31/32 & PTM-01/02...PSM-21/22

DN	15	20	25	40	50	65	80
R	1/2"	3/4"	1"	1 1/2"	2"	2 1/2"	3"
A	47	52	62	70	70	90	90

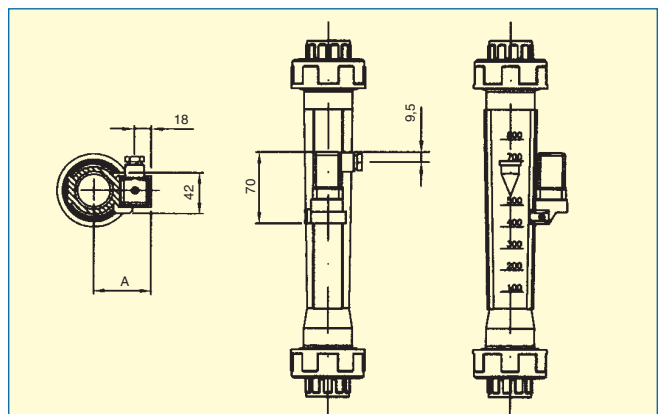

Transmitter PT-TMUR 0/4-20 mA (16...18 point)

(from 25-250 l/h H₂O and 0.8-8 Nm³/h air)

Transmitter PTM-TMUR 0/4-20 mA (11 points)

(from 6-60 l/h H₂O and 0.2-2 Nm³/h air)

The TMUR electric transmitter consists of a chain of reed switches which is mounted inside a plastic enclosure IP-65 rated which is attached to the side of the flow tube and a separated converted TR420 which converts the resistance in to current (0...4-20 mA). The converter TR420 can be installed by means of screws or in a DIN 46277 rail.

TR420 Converter Technical Data:

- Power supply: 110, 230, 240, 24 V ac 50/60 Hz
24 V dc
- Max. Power: < 1 VA
- Accuracy: ±0.1%
- Working Temperature: 0°C +60°C
- Electrical connection: 4 wires, standard
2 wires, on demand
- Resolution: 10 mm

(On request HART, PROFIBUS, FIELDBUS protocols)



TR420
(converter Ω/mA)



PTM/PSM + PTM-TMUR

PT/PS + PT-TMUR

PT-11/12 ... PS-31/32 y PTM-01/02 ... PSM-21/22

DN	15	20	25	40	50	65	80
A	95	105	110	120	130	145	145

TR420 Converter

Information for order a / vv

a = Output signal

- = A 0 - 20 mA
- = B 4 - 20 mA
- = D 0 - 5 V dc
- = E 0 - 10 V dc
- = F 1 - 5 V dc
- = G 2 - 10 V dc

vv = Supply

- = 110 110 V ac 50/60 Hz
- = 220 220-230 V ac 50/60 Hz
- = 240 240 V ac 50/60 Hz
- = 024 24 V ac 50/60 Hz
- = 24d 24 V dc

PT-11/PS-31 ... PT-12/PS-32 PTM-01/02 ... PSM-21/22 with TMUR

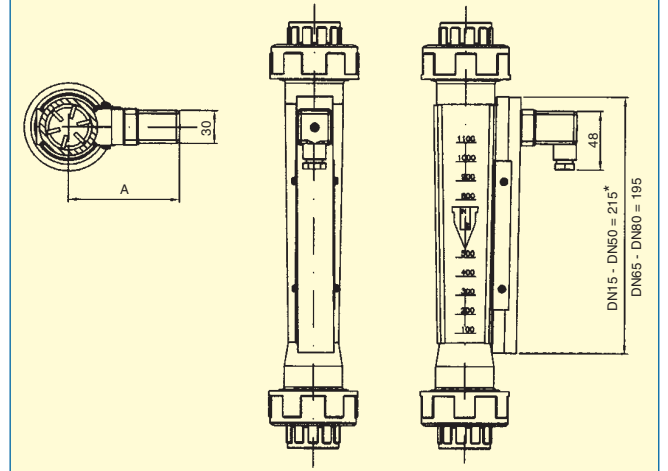

*PTM ... PSM 139 mm



Optional connections

PT-11/INOX (SS 316L = EN 1.4404)
Rp 1/2" ... 3" BSP/NPT



PT-11/INOX (SS 316L = EN 1.4404)
for welding
DN15 ... DN80



PT-11/PP
Rp 1/2" ... 3" BSP



PT-11 with nuts in PVC and
metallic end connectors:
PT-11/Fe, end connector in steel
PT-11/INOX, end connector in
SS 316L = EN 1.4404
Rp 1/2" ... 3" BSP/NPT



R+D, Manufacturing and assembly workshop



Machine shop



Sales department and calibration facilities



Glass workshop



We are at your service, please consult us.
TECFLUID develops and manufactures instruments for gases and liquids, using the most advanced techniques.
Request information by telephone nº: +34 93 372 45 11

C/. Narcís Monturiol, 33 - 08960 SANT JUST DESVERN (BARCELONA)
International: Telephone. +34 93 372 45 11 - Fax +34 93 473 44 49
www.tecfluid.com - e-mail: tecfluid@tecfluid.com

The technical data in this pamphlet is subject to modification without notification,
if the technical innovations in the product or manufacturing processes so require.