

FLOW METER

Model L

Model L is a sturdy variable area flow meter for industrial liquid and gas flow monitoring.



Model LH

FEATURES

- Plastic flow tube with stainless steel connections
- Flow adjustment valve
- Several flow ranges
- Clear, easy to read scale

TYPICAL APPLICATIONS

- Gas purging
- Water purging
- Liquid and gas flow monitoring

OPTIONS

- Scale for alternative gases and liquids
- Constant flow regulator
- Hand knob in flow adjustment valve
- Viton® or EPDM seals



Model L with constant
flow regulator model 2850



Technical data L

Model	LH -	LR -	LT -
Max. pressure	20 bar (30 bar/30 °C)	20 bar (30 bar/35 °C)	20 bar (30 bar/30 °C)
Max. temperature	75 °C	80 °C	70 °C
Flowtube	Acrylic (PMMA)	Grilamid (PA-12)	Trogamid-T (PA6-3-T)
Valve	AISI 316		
Connectors	AISI 316		
Seals	Nitrile (*Viton®, EPDM)		
Connections	NPT 1/4" (*BSP 1/4")		
Accuracy	±10% F.S. (H ₂ O, +20 °C)		
Weight	300 g		

*) Special construction on request

Special feature	
H	Hand knob in valve
R	Connections BSP 1/4"
V	Viton® -seals
Scale	
A	H ₂ O (l/min) at +20°C
R	Air (NI/min) at +20°C / 101,3 kPa
D	Relative scale 1-10
Flow range	
H ₂ O	Air
4K*	2 - 18 ml/min 0,1 - 0,9 NI/min
4A*	2,5 - 30 ml/min 0,1 - 1,2 NI/min
4B*	5 - 55 ml/min 0,2 - 1,8 NI/min
4C*	15 - 85 ml/min 0,5 - 2,5 NI/min
5K	0,01 - 0,13 l/min 0,5 - 6 NI/min
5A	0,01 - 0,2 l/min 0,5 - 7 NI/min
5B	0,025 - 0,35 l/min 1 - 10 NI/min
5C	0,05 - 0,5 l/min 2 - 14 NI/min
8T	0,1 - 0,75 l/min 3 - 20 NI/min
8M	0,1 - 1 l/min 5 - 30 NI/min
8P	0,2 - 1,6 l/min 5 - 50 NI/min
8S	0,2 - 2,6 l/min 10 - 85 NI/min
8R	0,5 - 3 l/min 10 - 110 NI/min
Flow tube material	
H	Acrylic
R	Grilamid TR 55
T	Trogamid-T

* Accuracy is not guaranteed

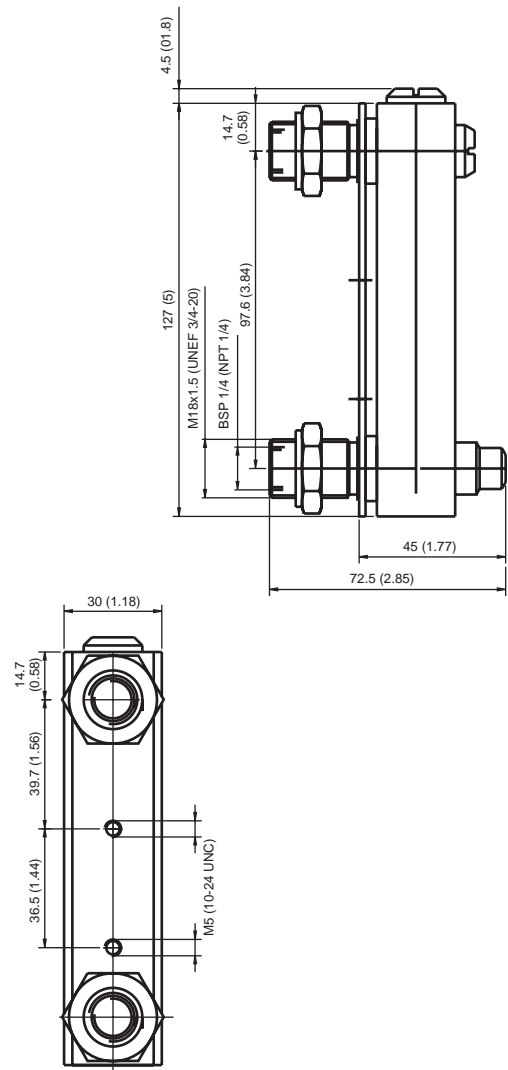

mm (in)

MANUFACTURER

Kytola
INSTRUMENTS

KYTOLA OY • Olli Kytolan tie 1
P.O. Box 5 • FI-40951 MUURAME • FINLAND
Phone +358 14 339 0600 • Fax +358 14 631 419
E-mail sales@kytola.com • www.kytola.com

LOCAL REPRESENTATIVE